

BEFORE YOU BEGIN

- Please read these instructions carefully to familiarize yourself with the required tools, materials, and installation sequences. Follow the sections that pertain to your particular installation. This will help you avoid costly mistakes. In addition to proper installation, read all operating and safety instructions.
- All information is based on the latest product information available at the time of publication. Kohler China Ltd. reserves the right to make changes in product characteristics, packaging, or availability at any time without notice.
- These instructions contain important care, cleaning, and warranty information-**please leave these instructions for the consumer.**
- **IMPORTANT:**
All installations must comply with council and local authority by-laws. It is the responsibility of the installer to ensure that the waste is made watertight by means of silicone sealant or caulking compound.

安装之前

- 请仔细阅读此说明书以熟悉所需要的工具、材料及安装顺序。遵循适合您的特定安装要求的各项内容，避免昂贵的损失。除了要正确安装外，还应阅读操作及安全说明。
- 所有的资料是按最新出版的产品资料编写而成。科勒中国有限公司保留任何时候无须通知即可改变产品特性、包装或产品可供类型的权利。
- 说明书包括重要的安装、清洁及保养方面的内容，**请把这些资料交给用户阅读。**
- **重要信息：**
所有安装必须符合行业理事会和地方政府的章程。安装人员有责任保证使用硅胶或填缝材料使污水不泄漏。

PRODUCT REQUIREMENTS

A. Product Requirements

- Observe all local plumbing codes.
- Install the unit to a level subfloor.
- Provide properly-dimensioned framing.
- Baths are designed for a variety of installations, depending upon the model chosen.

B. Product Inspection

Uncrate and inspect bath for damage. Leave all materials in the crate during construction to prevent damage.

产品要求

A. 关键要求的总结

- 请遵守当地的卫生管道施工规范。
- 在水平的未装修地板上安装浴缸。
- 提供适当尺寸的结构。
- 浴缸的设计适用于不同的安装方式，请按型号来选定。

B. 产品检查

小心地打开包装箱并检查浴缸是否损坏。施工期间将所有的材料都留在箱内，以防止损坏。

ROUGHING-IN

安装尺寸

● STUDIO K-11201T-W02

● 思都 K-11201T-W02

A. Ordering Information:

A. 订购信息:

Accessories/Hardware		
Drain	17295T-CP	Optional

装饰/配件		
排水	17295T-CP	推荐使用

B. Product Information:

B. 产品资料:

Fixture*	Basin area	Top area	Weight
Bathing well	1100×430mm	1540×640mm	23kg
	Water depth	Capacity	
To overflow	475-490mm	231L	

* Approximate measurements for comparison only.

浴缸	底部	顶边	重量
面积	1100×430毫米	1540×640毫米	23公斤
	深度	容积	
到溢水口	475-490mm	231升	

*为比较浴缸所用的参考数值。

C. Roughing-in:

C. 尺寸图:

UNIT: mm
单位: 毫米

STUDIO 思都
K-11201T-W02

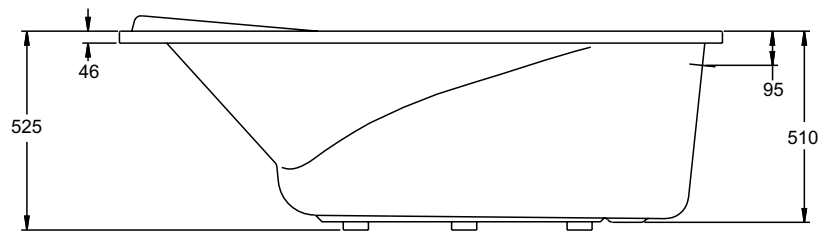

排水口: $\varnothing 50$
Diameter of drain hole: $\varnothing 50$
溢水口: $\varnothing 52$
Diameter of overflow hole: $\varnothing 52$

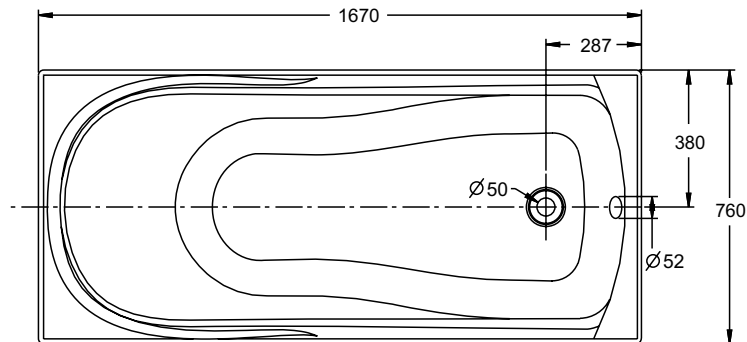

● STUDIO K-17107T

● 思都 K-17107T

A. Ordering Information:

A. 订购信息:

Accessories/Hardware		
Drain	17295T-CP	Optional

装饰/配件		
排水	17295T-CP	推荐使用

B.Product Information:

Fixture*	Basin area	Top area	Weight
Bathing well	955×430mm	1392×635mm	19kg
	Water depth	Capacity	
To overflow	475-490mm	212L	

* Approximate measurements for comparison only.

B.产品资料:

浴缸	底部	顶边	重量
面积	955×430毫米	1392×635毫米	19公斤
	深度	容积	
到溢水口	475-490mm	212升	

*为比较浴缸所用的参考数值。

C.Roughing-in:

C.尺寸图:

UNIT: mm
单位: 毫米

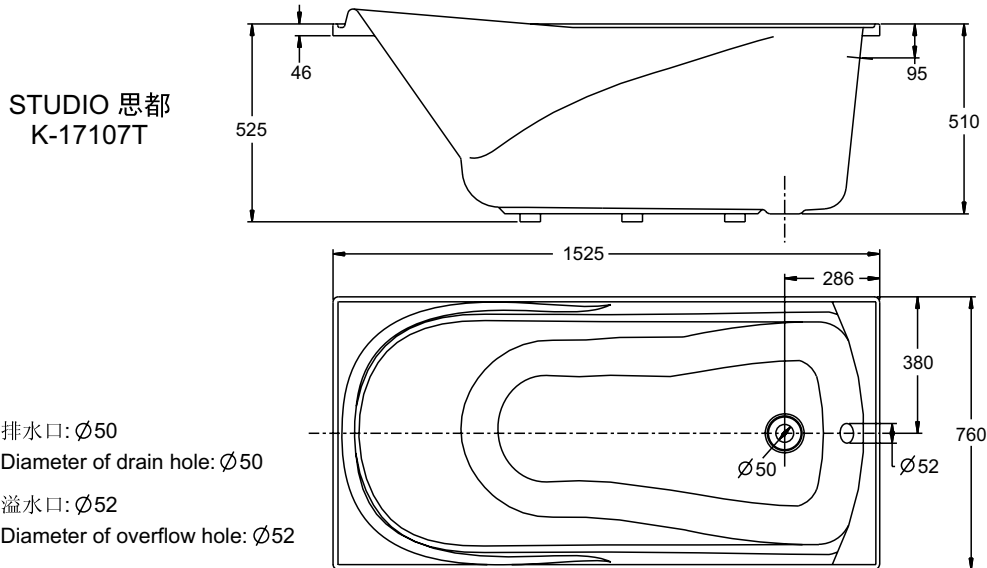

INSTALLATION REQUIREMENTS

安装要求

A. Tools Required B. Materials Required

- | | |
|--------------------------|------------------------------------|
| • Adjustable pipe wrench | • Plumbers putty |
| • Rule | • Wall coverings, as necessary |
| • Level | • Silicone sealant |
| • Safety shoes | • Gypsum cement (optional) |
| • Safety glasses | • Construction adhesive (optional) |
| • Square | • Protective covering for bathtub |
| • Screwdriver | • Nails |
| • Pliers | |
| • Utility knife | |

A. 所需工具

- 管道扳手
- 刻度尺
- 水平仪
- 安全鞋
- 安全眼镜
- 直角尺
- 螺丝刀
- 钳子
- 多用工具刀

B. 所需材料

- 管道用油灰
- 墙面保护罩(如需要)
- 密封硅胶
- 石灰水泥(选用)
- 建筑粘胶(选用)
- 浴缸保护套
- 钉子

C. Clearance Requirements

Check the rough-in and room dimensions to provide adequate available space for the bath unit.

C. 预留尺寸

检查安装尺寸及浴室尺寸, 确保有充分的空间安装浴缸。

SITE REQUIREMENTS

场所要求

A. Old Bath Removal

Disconnect the drain at the trap. Remove the old wall material. Slip boards under the old bath feet to protect the floor, and slide the old bath out of the recess as illustrated.

A. 拆除旧浴缸

在存水弯处拆下排水管。清除所有旧墙材料。在旧浴缸下面塞入护板以保护地面，并按如图所示把旧浴缸从安装空间拉出。

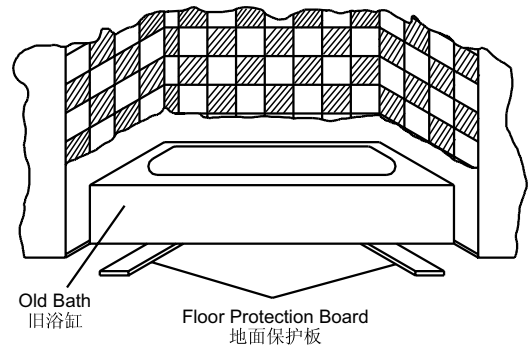

B. Subfloor Preparation

Check the flooring under the bath, and make repairs as needed. Make sure the subfloor is level.

B. 底层地板的准备

检查浴缸下的地板，若需要请进行修补。请确保底层地板水平。

C. Bath Area Construction preparation

Possible framing arrangements are illustrated below. Use the framing construction appropriate for your particular bath model. Some modifications may be needed for other types of construction, if preferred.

C. 浴缸支撑结构的准备

下图所示为几种常用的支撑结构，请采用适合您的浴缸型号的结构。对不同的支撑结构方式，也许有必要进行适度调整。

Recommended For Drop-in Models

下列建议适合为无裙边浴缸使用

1). Corner Installation

The suggested framing construction is illustrated.

1). 墙角安装

右图为建议的支撑结构。

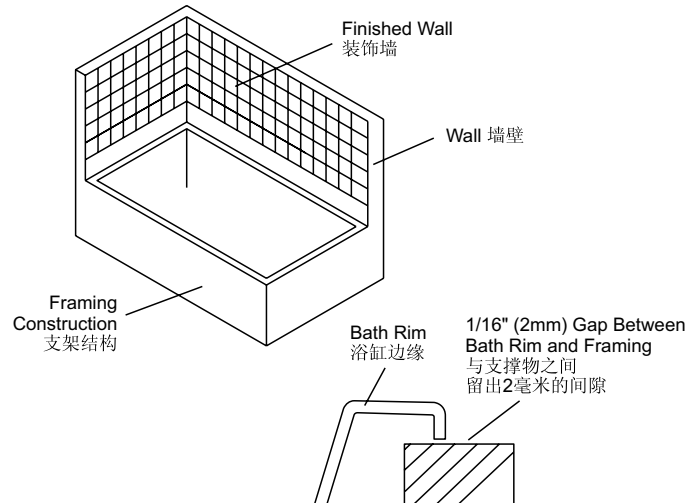

2). Recess Installation

The suggested framing construction is illustrated.

2). 三面靠墙安装

建议的三面墙环围的支撑结构如图所示。

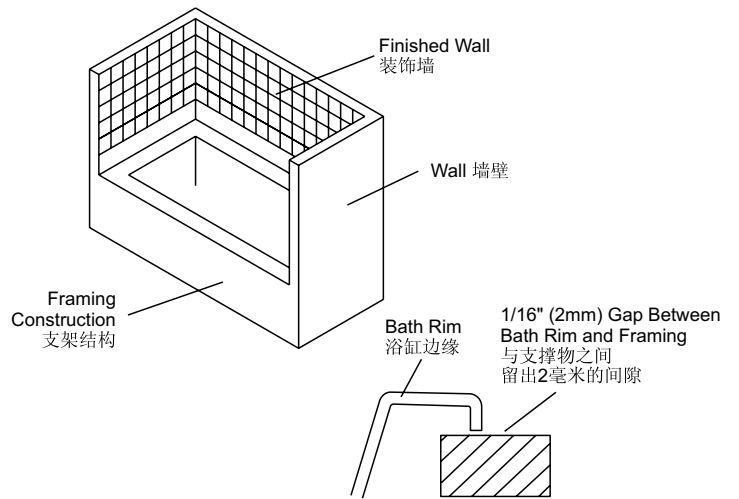

3). Peninsular Installation

The suggested framing construction is illustrated.

3). 单面靠墙安装

建议的单面墙支撑结构如图所示。

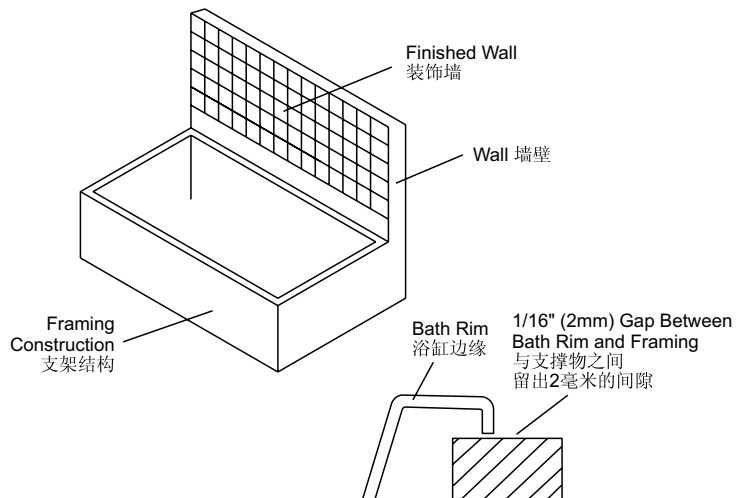

4). Sunken Installation

Refer to rough-in notes on page 1 for cut-out details.
Do not hang the bath by the rim.

4). 嵌入安装

有关切割图样的细节，请参阅第一页上的安装尺寸说明。
不要使浴缸靠边缘悬挂。

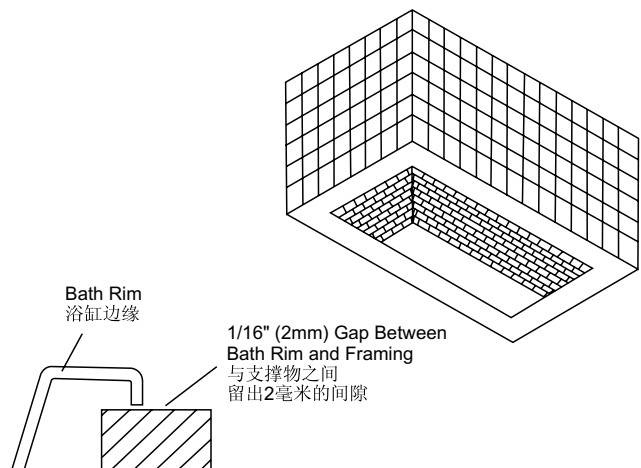

D. Plumbing Preparation

Position the plumbing according to rough-in dimensions.
Cap the supplies and check for leaks.

D. 管道的准备

将管道按安装尺寸安置，堵塞供水管并检查是否漏水。

BEFORE INSTALLING UNIT

A. Your new bath has been manufactured to the highest possible standards. However please inspect for any possible damage that may have occurred in transit.

NOTE: Warranty does not cover damage to bath caused in transit or installation.

B. The protective film must be removed from around the waste and along the tiling bead prior to installation in order to make a watertight seal at these points possible.

C. Partially Install Bath Drain

Install the drain on the bath according to the drain manufacturer's instructions.

D. Protect the Bath Unit

Position a protective covering or similar material in the bottom of the unit. Be careful not to scratch the bath surface.

INSTALL THE BATH

A. Locate the Bath in the Proposed Position.

IMPORTANT: The bath must be installed level on all top edges. The rim and the base of the bath must be fully supported. Floor should be flat, level and free of any bumps or protrusions.

Remove protective film around the waste and along the tiling bead prior to installation in order to make a watertight seal at these points possible.

A. 将浴缸放在合适的位置。

注意：浴缸必须水平安装。浴缸的边缘和底部需全部支撑。底层地板必须水平。不得有凹凸不平的现象。为了给一些部位做防水密封，安装前请将排水处及防水条处的保护层拿掉。

NOTICE: Do not hang the bath by the rim.

Apply a generous amount of fine construction mortar, or similar material, to the support feet and any shims used. Set the bath into the installation. Make sure the unit is level, and is resting on all support feet. Insert the drain tailpiece into the trap.

注意：不要靠边缘将浴缸悬挂。

在支角和垫片上涂足够量的泥灰浆或类似材料，将浴缸放入安装位置。确保浴缸水平放置，并且所有重量都均匀地承载在支脚上。将排水管尾端插入存水弯。

安装浴缸之前

A. 本浴缸质量上乘。但在搬运过程中，可能会遭到损坏。请仔细检查。

注意：搬运或安装过程中所造成的损坏，不能获得保修。

B. 安装前，必须将排废水处及防水边四周的保护层拿掉。

C. 局部安装浴缸的排水配件

按照厂家说明书，把排水配件部分安装在浴缸上。

D. 保护浴缸

在浴缸表面盖上保护套或类似的材料，小心不要划伤浴缸表面。

安装浴缸

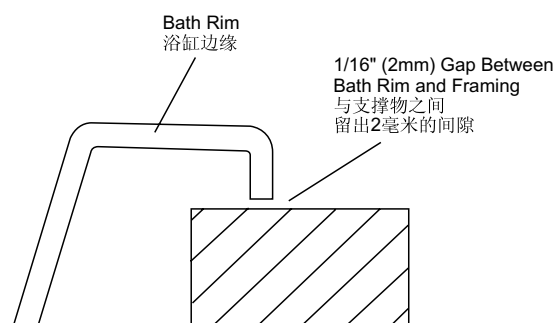
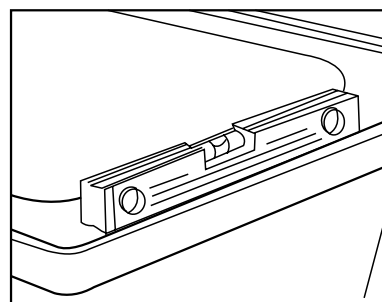

B. Base Support

Method 1

Floor should be flat, level and free of any bumps and protrusions. Ensure support feet are fully supported. Bricks can be placed under the support feet to allow access to waste fitting if necessary.

Method 2

Install the bath in a bed of weak mortar slurry mix (6:1) ensuring the base is fully supported. If the installation is with above floor plumbing, ensure that free access to pipes and waste fitting is provided.

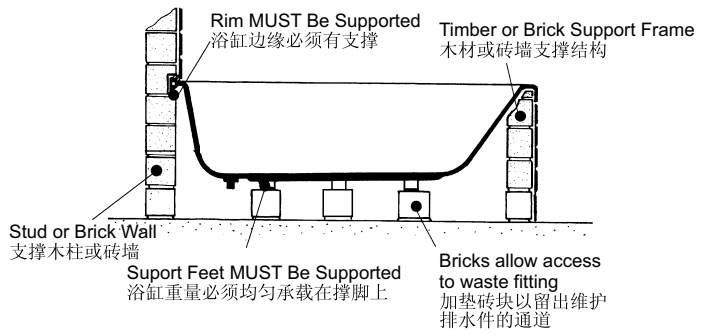

B. 底部支撑

方法1

底层地板必须水平，不得有凹凸不平的现象。保证全部支撑脚全部得到支撑。如果需要安装排水配件可在支撑脚下加垫砖块创造通路空间。

方法2

将浴缸安装在一层薄薄的灰浆层上(6:1)。保证浴缸底部全部得到支撑。如果安装场地的管道铺设情况是在地面上的话，请确保排水配件及水管有足够的通路空间。

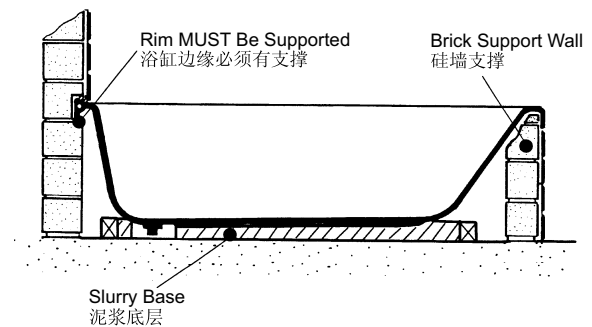

C. Bath Rim Support

Drop-In Models:

CAUTION: After the bath is securely positioned and bath rim well supported, please complete step D; install the plumbing and check the unit for leaks. When you are happy with the results proceed with step 1 and step 2 below.

- 1). Install the ceramic or marble tiles. Seal the joints between the bath rim and the finished tiled wall using silicone sealant. RTV (Room Temperature Vulcanizing) sealant is recommended.
- 2). For sunken type installation, construct the ceramic or marble tiles. Seal the joints between the bath rim and the tiled wall with silicone sealant.

C. 完成浴缸边缘处的安装

无裙边浴缸类型:

注意！！ 当浴缸安放到位并且浴缸边缘得到完全支撑的情况下完成步骤D: 安装卫生管道并检查排水是否有渗漏。检查通过后才开始以下1), 2)步骤。

- 1). 安装墙壁贴面(如瓷砖或大理石)。用硅胶密封浴缸边缘和贴面的连接处。建议使用常温下硬化的密封胶。**注意:** 为了有最佳的防水效果, 建议将防水边处敷上瓷密封。
- 2). 对嵌入式安装, 在敷上瓷砖或大理石贴面后, 再用硅胶密封浴缸边缘和贴面的连接处。

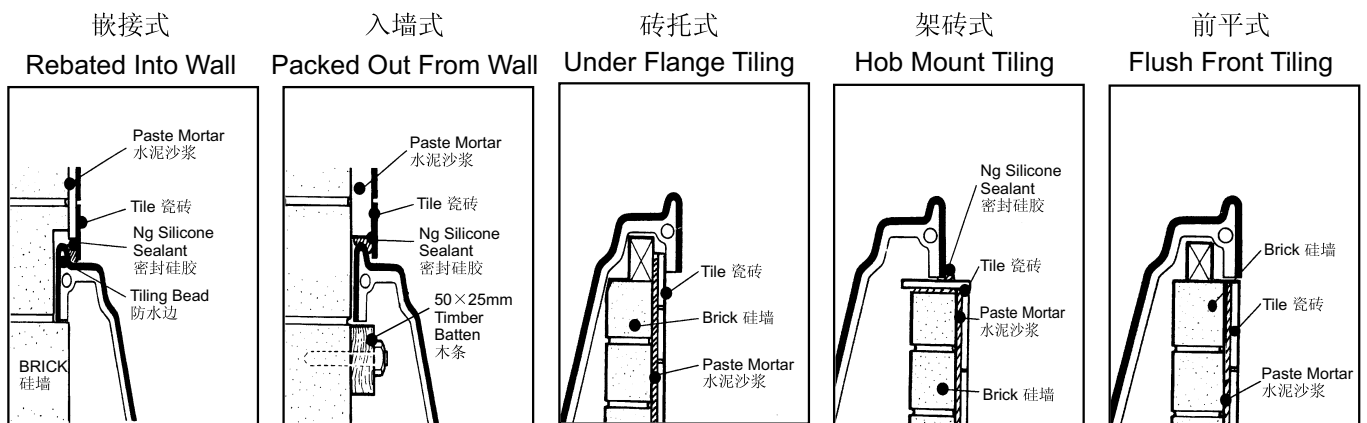

D. Install Plumbing

CAUTION: Risk of damage to bath bottom and subfloor. Ensure a watertight seal on the bath drain connections.

- 1). When the bath is securely positioned, connect the drain to the trap.
NOTE: An access panel will simplify future maintenance.
- 2). Install the faucet valving and spout tee. Open the hot and cold water valves, and check the supply connections for leaks.
- 3). Run water into the bath, and check the drain connections for leaks.
- 4). Fill the bath up to the overflow level and check overflow for any leaks.

D. 安装卫生管道

注意！！ 避免损坏浴缸底部和底层地板。浴缸的所有排水接口都要确保做防渗密封。

- 1). 当浴缸固定到位后，将排水管与存水弯相接。
注意： 为方便以后维修，一定要安装一个检修门。
- 2). 安装水龙头阀门及喷头三通。打开冷水及热水阀门，检查所有给水管接头是否有渗漏。
- 3). 将浴缸注入水，检查排水配件接头是否有渗漏。
- 4). 注水至溢水口高度，检查溢水口是否有渗漏。

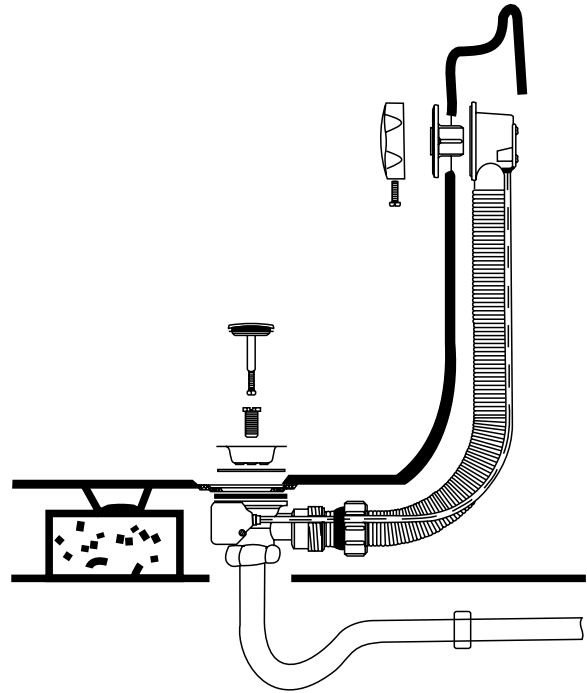

DRILLING AND CUTTING ACRYLIC

DRILLING: Small holes can be drilled with a twist drill, but the cutting edge **MUST** be backed off with an oil stone (the sharp edge dulled). Large holes must be drilled with a hole saw. Maximum drill size-12mm. Drill speeds-6mm x 1800 RPM-12 mm x 900 RPM.

NOTE: Always drill from acrylic surface.

CUTTING: If for any reason the acrylic requires cutting, use a fine tooth hacksaw and proceed with caution. Edges can be smoothed with a second-cut file and medium-fine sandpaper. If the surface of the acrylic should happen to be damaged, it can be restored by polishing with an abrasive cleaner. Deep scratches can be removed by rubbing with 600 grade wet & dry sandpaper then polishing.

在亚克力表面上钻孔和切割

钻孔： 可用一麻花钻头钻小孔，但切削刃必须用一块油石磨钝。大孔须用孔钻加工。麻花钻头的最大尺寸为12mm，速度为6mmx1800转/分至12mmx900转/分。

注意： 钻孔要从亚克力表面钻向浴缸背面。

切割： 如果因故需要切割亚克力，请用优质齿型钢锯仔细切割。边缘可用一旧锉刀及中等砂纸磨平。如果亚克力表面受损，可用磨蚀性清洁剂抛光，将其恢复。深度刮伤可用600号水砂纸磨平，然后抛光。

CLEAN-UP AFTER INSTALLATION

When cleaning up after installation, do not use abrasive cleansers as they may scratch and dull the surface. Use warm water and liquid, non-abrasive detergent to clean the surface.

Stubborn stains, paint, or tar can be removed with mineral spirits. Do not use cleaners containing solvent. Plaster can be removed by scraping with wood edge. Do not use metal scrapers, wire brushes, or other metal tools. One of the powder type detergents may be used on a damp cloth to provide mild abrasive action to the residual plaster.

完工清理

在安装完成后进行清理时，请勿使用磨损性的清洁用具，以免擦伤浴缸表面，使其失去光泽。使用温水和非腐蚀性的液体清洁剂，清洗浴缸表面。

难以清除的污迹、油漆、或柏油，可用酒精擦净。请不要让含有溶剂的清洁剂。滞留水泥可用薄木刀刮掉。请不要使用金属刮刀，钢丝刷，或其它金属工具。对残留的水泥浆，可用湿布粘些洗衣粉，以提供轻微的研磨作用。

IMPORTANT CONSUMER INFORMATION

A. Consumer Responsibilities

Cleaning Acrylic Surfaces: Do not use abrasive cleansers on any acrylic surfaces, as they will scratch and dull the surface. Wipe out the bath after each use to prevent a build-up of soap and scum.

If the acrylic surface becomes dull, an automotive type rubbing compound *may be used on the unit, followed by an application of paste wax.

*We recommended:

Rubbing compound mequiars mirror glaze 28 metal polish (import product) or "green oil".

重要的用户资料

A. 用户的责任

清洗亚克力表面：请勿在亚克力表面使用磨损性的清洁用具，以免擦伤浴缸表面，使其失去光泽。每次使用后，将浴缸擦干，以防止肥皂和污垢沉积。

若亚克力表面失去光泽，先用汽车抛光剂*，然后再用粗腊打亮。

*我们推荐使用以下2种抛光剂：

- ① Mequiars 镜面光亮28金属上光剂。(进口)
- ② 抛光膏(绿油)。

LIMITED ONE-YEAR WARRANTY

一年有限担保

Plumbing Fixtures and Fittings Limited One-year Warranty

Kohler plumbing fixtures and fittings are warranted to be free of manufacturing defects.

This product is warranted for one year from date of purchase. Kohler China will be responsible for any problems caused by manufacturing defects provided with the invoice. Kohler China will, at its election, repair, replace or make appropriate adjustment where Kohler China inspection discloses any such defects occurring in normal usage within one year after purchase.

Implied warranties including that of merchantability and fitness for a particular purpose are expressly limited in duration to the duration of this warranty, Kohler China disclaims any liability for special, incidental or consequential damages. Damages to the product caused by misuse, abuse and installation that is not in accordance with the owner's manual are not covered by this warranty.

To obtain quick warranty service, please contact your dealer, or write to Kohler China. (Original sales receipt must be provided as the proof of purchase.)

Kohler China Investment Company Ltd.
Central Customer Service Center
19/F, Shanghai Square, 138 Huai Hai
Road, Luwan District, Shanghai, PRC
Zip Code: 200021

This is our exclusive written warranty.

陶瓷及浴缸产品及配件担保——一年有限担保

科勒公司担保其陶瓷及浴缸产品及配件在制造工艺上无瑕疵。

本产品自购买之日起即获得本公司一年的质量保证。在质保期内，凭购货发票，科勒公司将免费承担由制造质量引起的任何问题。经核查后，科勒中国有限公司有权决定是修理、更换、还是作适当的调整。

这里所指的担保，包括产品，都已明确地限制在该担保期之内。科勒中国有限公司对其后出现的损坏不负有任何责任。担保也不包括外观损伤、使用不当以及未按说明书安装的损失。

为获得快捷的担保服务，请联系您的销售商；您也可写信给科勒中国有限公司(请出示销售发票原件作为购货凭证)：

科勒(中国)投资有限公司
中央客户服务中心
上海市卢湾区淮海中路138号
上海广场19楼
邮编：200021

这是我们全部的书面担保。